

Sensing Vibrations

Accelerometers SA 500x /510x / 2011



Advantages

- High sensitivity
- Rugged

Applications

Capturing mechanical vibrations on grinding machines

Sensors for the active Balancing System HB 6000

Options

- Cable length
- Various connectors
- Retaining magnet
- Probe

Description

The SA xxxx series vibration transducers are used to convert mechanical vibrations into analogue alternating electric signals. Due to their high sensitivity, they can be used on typically rigid grinding machines.

The sensors differ in sensitivity and design.

The accelerometers of the SA series correspond to the former Hofmann BM models.

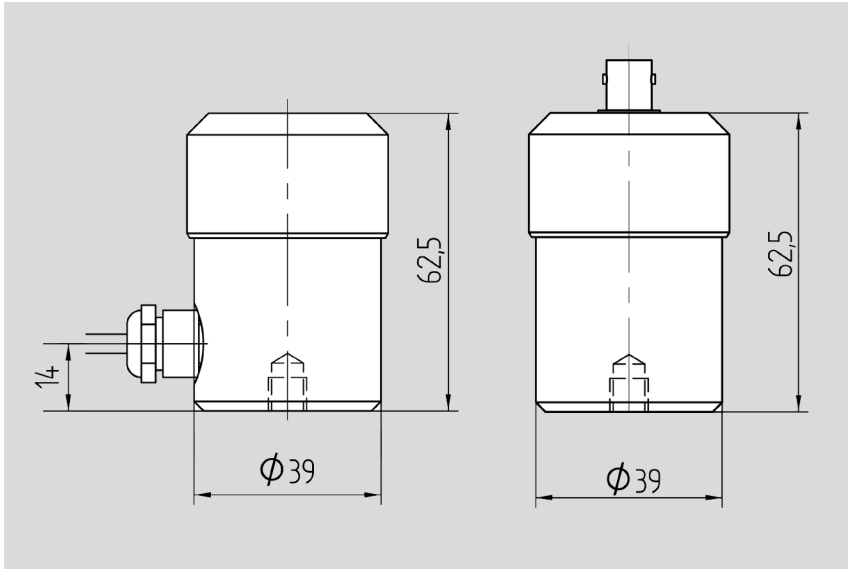

SA sensor with non-removable cable or BNC socket

Technical data

Input	Vibration acceleration	
Orientation	any spatial orientation	
Measuring direction	in the direction of cylinder axis	
Reference system	Absolute vibration transducer	
Physical principle of measurement	Piezo	
Mounting	M5 screw	
Output	Alternating electric voltage	
Weight	approx. 300 g	
Housing material	Stainless steel, non-magnetic	
Operating temperature	0 to +60 °C	
Connection	BNC connector or non-removable 4 m cable with BNC or 4 pin Binder connector	
Protective rating	IP 65	
Output voltage	SA 5004 SA 5005 SA 5100/ 5101 SA 2011	5000 mV/g 1000 mV/g 20 mV/ mms-1 1200 pC/g
Internal resistance	approx. 150 Ω	
Operating frequency range	0.5 dB	10 to 50 Hz
	3 dB	5 to 200 Hz
Measurement range	0.05 to 5 g	0.5 to 50 m/sec. ²
Acceleration, max.	50 g	
Directional sensitivity	better than 1:20	